

LJR type horizontal plate clamp

For intensive use

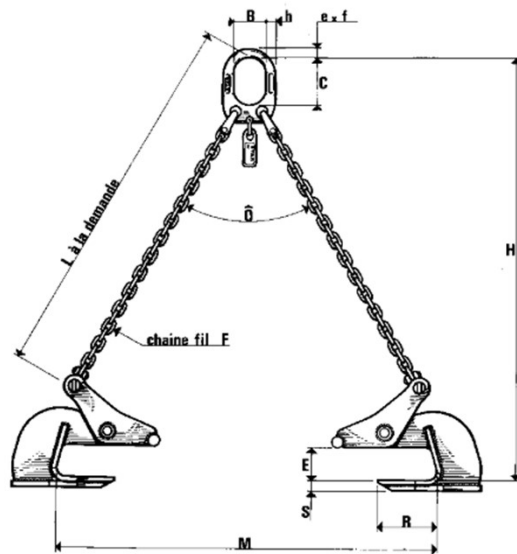

- Very large capacity
- Chain class 8 (CEN TC 168)
- Coefficient of use : clamp 5 chain 4
- All length « L » and all forces on request

With chain

SWL of 2 clamps 45° kg	B mm	C mm	e mm	f mm	Capacity E mm	F mm	L m	Mass kg	Mass of add meter kg	SWL of 2 clamps according to angle δ of the 2 sides, kg			SAPEM code
										60°	90°	120°	
1 000	70	105	14	20	0 / 60	7	2	15	2.2	800	700	500	1781A
					0 / 100								1782A
2 000	70	105	14	20	0 / 60	7	2	17	2.2	1 700	1 400	1 000	1781B
					0 / 100								1782B
3 000	80	120	18	21	0 / 60	8	2	21	2.8	2 500	2 100	1 500	1781C
					0 / 100								1782C
5 000	105	158	28	31	0 / 60	13	2	35	7.6	4 200	3 500	2 500	1781D
					0 / 100								1782D
7 000	110	165	30	34	0 / 60	13	2	50	7.6	6 000	4 900	3 500	1781E
					0 / 100								1782E
10 000	110	165	30	34	0 / 60	16	2	98	11.4	8 500	7 000	5 000	1781F
					0 / 100								1782F
15 000	120	180	36	42	0 / 60	19	2	140	16	13 000	10 500	7 500	1781G
					0 / 100								1782G
20 000	130	195	40	46	0 / 60	22	2	175	21.8	17 000	14 000	10 000	1781H
					0 / 100								1782H

Note: Equipment meeting the essential requirements of European Directive 2006/42/CE. Supplied with "CE" certificate of conformity.